

Water Heater Installation & Repair

Product Catalog

About RWC

Established in 1949, RWC is a global leader and manufacturer of plumbing solutions for residential and commercial applications. Through our trusted portfolio of leading brands, we strive to continuously find solutions that help make our customers lives easier and more efficient.

Global scale, local service



14
Manufacturing
Facilities



29
Distribution
Centers



70+
Years of
engineering
experience



250+
Patents



The complete solution from our family of trusted brands

From pipe and fitting systems to firestopping, gas connectors and valves, our innovative products are designed to make plumbing better.



Pipe and Fitting Systems



Valves and Supply Stops



Firestopping



Appliance and Fixture Boxes



Secondary Pipe Supports



Supply Lines and Connectors



Water Heater Accessories



Gas Connectors and Valves



Water Heaters

Water Heater Tank

RWC's family of industry leading brands provide a comprehensive offering of water heater accessories with solutions that range from increasing water heater capacity, to protecting the water heater system, to providing water heater supports, connectors, expansion tanks, drain pans, stands and other accessories.

All designed to streamline your water heater installation using trusted brands backed by one manufacturer.



Tankless Water Heater

Engineered to prevent dangerous pressure build-ups, tankless water heater accessories ensure safety and reliability. Featuring gas connectors and isolation valves, these solutions simplify installation and maintenance while providing best-in-class safety to protect your tank



Water Heater Connectors

Corrugated Stainless Steel

Water heater connectors are a premium corrugated stainless steel. Featuring deep corrugations in the stainless steel, this connector provides robust structural support, effectively guarding against crushing, kinking and cracking.



Braided Water Heater Connector

Designed to offer strength and flexibility, these braided water heater connectors provide a dependable, leak-proof connection. With easy installation, they serve as a durable solution for efficiently supplying water to your heater, ensuring long-lasting performance.



Gas Connectors

Many Configurations

Our connections cover a range of BTU's and connection types and are available in various lengths.

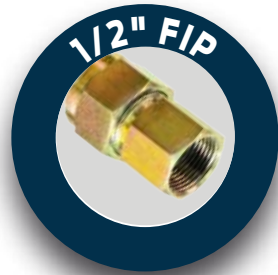

Quality Certifications



The Safety of Your Home and Family Depends on the Quality of Gas Connectors You Choose

RWC is now offering a complete line of flexible connectors for gas applications.

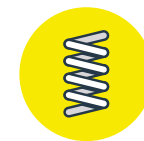

Corrugated Stainless Steel

Available with yellow and black epoxy coating for improved corrosion resistance. Easily identifiable as a gas connector.

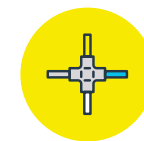

Many Configurations

Our connectors cover a range of connection types and BTUs up to 290,900.



Easy to Install

Deep corrugations enhance flexibility.



100% Leak Tested

Factory tested for peace of mind.

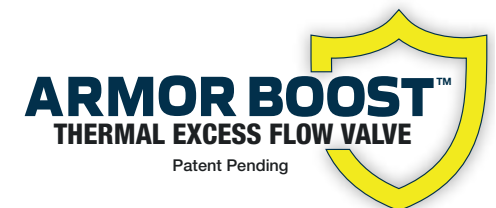
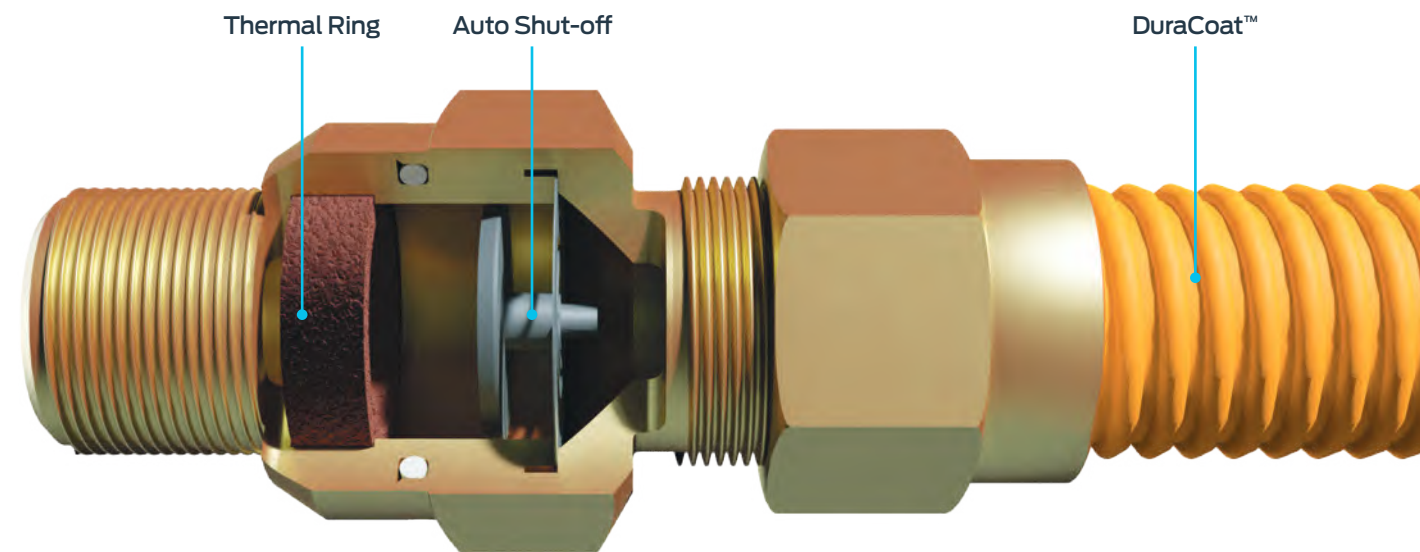
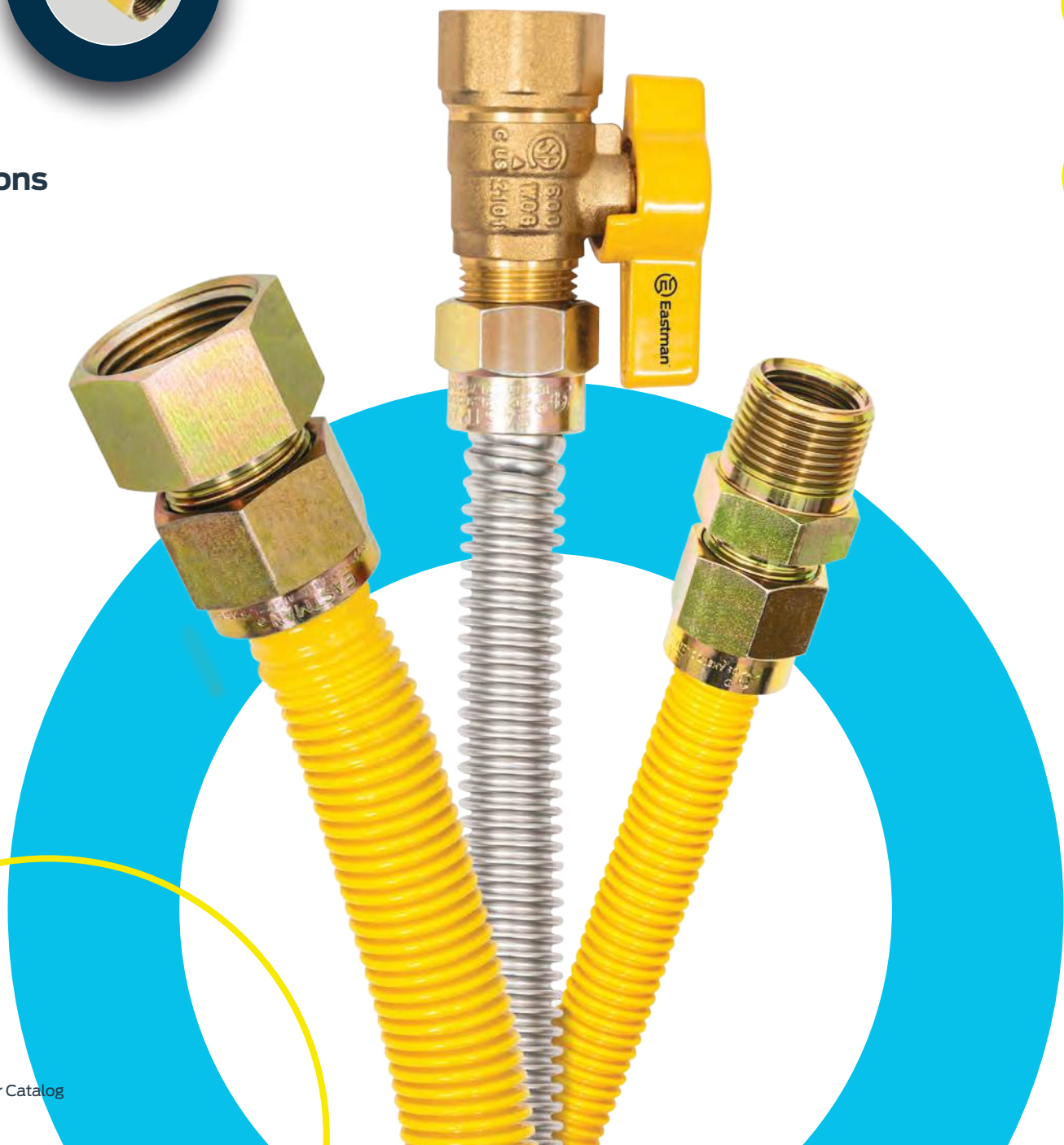

Contents

12 WaterFlex™ Corrugated Stainless Steel Connectors

Installation Kits	14
Connection Kits	15
Connectors	16

22 WaterFlex™ Braided Stainless Steel Connectors

Braided Connectors	24
Braided Swivel Connectors	27

28 Water Heater Installation

Thermal Expansion Relief Valve	30
Thermal Expansion Tanks	30
Expansion Tank Tee	31
Expansion Tank Mounting Brackets	31
Thermostatic Mixing Valves	32
Vacuum Relief Valve	32
Gas Connectors	33
Tankless Installation Kit	34
Tankless Service Valve Kit	34
Runoff Tube	35
Drain Elbow	36
Dip Tube	36
Heat Trap Nipples	36
Dielectric Unions	37
Earthquake Straps	38
Water Heater Sheds	39

42 Water Heater Pans

Plastic Water Heater Pans	42
Aluminum Water Heater Pans	43
Water Heater Pan Fitting	44
Galvanized Water Heater Pans	44
Water Heater Stands	45

48 Water Heater Repair

Anode Rods	48
Drain Valves	49
Thermocouples	49
Temperature and Pressure Relief Valves	50
Pressure Relief Valves	50
Electrical Continuity Tester	52
Tune-Up Kit	52
Heating Elements	53
Tools	54
Adapter Kit	55
Replacement Parts	55
Thermostats	56



Corrugated Stainless Steel Connectors

Installation Kits	14
Connection Kits	15
Connectors	16



Installation Kits

SharkBite Max™ Stainless Steel Corrugated Flexible Water Heater Connection Kit

Features and benefits

- Integrated ball valve for easy shut-off
- Can be used as an alternative to hard piping
- Approved for electric and gas water heaters with flue venting

Includes

- 3/4 in. FIP x 3/4 in. SharkBite 18 in. Corrugated Water Heater Connector (URSS3088FX18)
- 3/4 in. FIP x 3/4 in. SharkBite 18 in. Corrugated Water Heater Connector with Ball Valve (URSS3088FX18BV)
- 3/4 in. Disconnect Clip (U712)

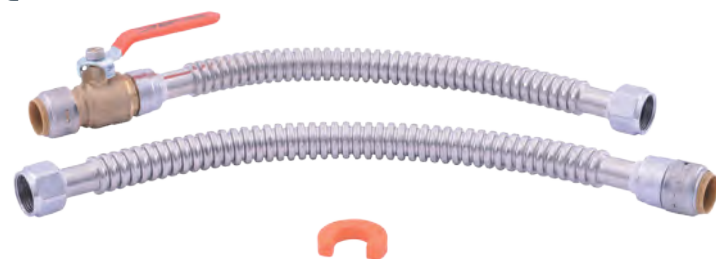

Part #	Description
UR24680	Water Heater Connector Kit

Eastman™ WaterFlex™ Gas Water Heater Installation Kit

Features and benefits

- 18 in. Water connectors are durable corrugated stainless steel
- 24 in. Gas supply is long-lasting, corrosive-resistant, flexible corrugated stainless steel
- Included lead-free brass adapters allow solder-free connection to copper pipe
- Kit includes everything to connect gas and water supplies to a new or existing gas water heater

Includes

- Flexible water supply connectors
- Compression adapters
- Roll of sealing tape
- Gas Connector



Part #	Description
48280	Gas Water Heater Installation Kit

Installation Kits

Eastman™ WaterFlex™ Electric Water Heater Installation Kit

Features and benefits

- 18 in. Water connectors are durable corrugated stainless steel
- Included lead-free brass adapters allow solder-free connection to copper pipe
- Kit includes everything to connect water supply to a new or existing electric water heater

Includes

- 18 in. Flexible water supply connectors
- Compression adapters
- Roll of sealing tape



Part #	Description
48281	Electric Water Heater Installation Kit

Connection Kits

SharkBite Max™ Water Heater Connection Kit

Features and benefits

- Compatible with PEX, Copper, CPVC and PE-RT pipe
- No special tools, crimping, glue or soldering needed
- Can be installed in wet lines
- Can be rotated for easier and faster installation
- Ideal for working in tight spaces
- Remove using Disconnect Clip (included)

Includes

- Female Connectors
- Disconnect Clip



Part #	Description
22604LF	1/2 in. x 3/4 in. FNPT
22441LF	3/4 in. x 3/4 in. FNPT

Connectors

SharkBite Max™ Water Heater Connector with Ball Valve

Features and benefits

- Fastest way to install a water heater with PEX, Copper, CPVC, PE-RT or HDP SDR-9 pipe*
- Can be installed on wet lines and pressure tested immediately
- Integrated ball valve for easy shut-off

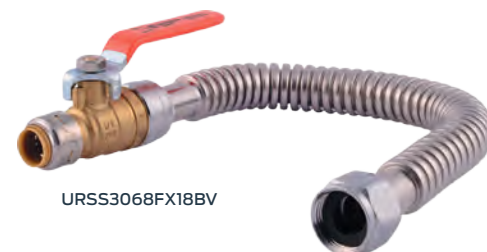

URSS3068FX18BV

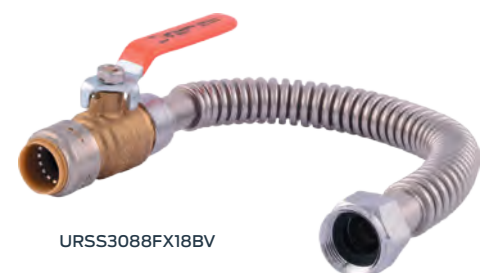

URSS3088FX18BV

SharkBite™ Brass Expansion Water Heater Connector

Features and benefits

- Can be used as an alternative to hard piping
- Compatible with PEX-A
- Ideal for working in tight spaces



Part #	Description
UAB3088FXSS18LF	3/4 in. x 3/4 in. FIP x 18 in.

Connectors

Eastman™ WaterFlex™ 3/4 in. x 3/4 in. Connector

Features and benefits

- Corrugated stainless steel
- Nickel-plated brass nuts
- Nitrile rubber sealing washer



437012



438612



437118



437412

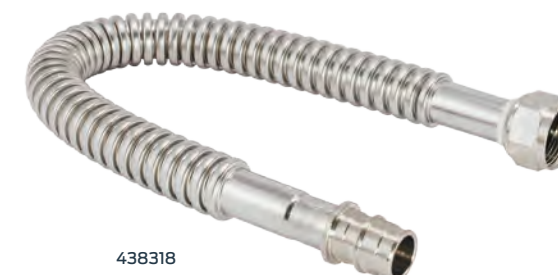

438318

3/4 in. FIP x 3/4 in. FIP

Part #	Description
437012	12 in.
437015	15 in.
437018	18 in.
437024	24 in.

3/4 in. FIP x 3/4 in. F1807 PEX

Part #	Description
438612	12 in.
438618	18 in.
438624	24 in.

3/4 in. FIP x 3/4 in. FIP – Epoxy coated, pair

Part #	Description
437118	18 in. – Pair Red & Blue
437124	24 in. – Pair Red & Blue

3/4 in. FIP x 3/4 in. Female Sweat

Part #	Description
437412	12 in.
437415	15 in.
437418	18 in.
437424	24 in.

Eastman™ WaterFlex™ 3/4 in. FIP x 3/4 in. F1960 PEX connector

Part #	Description
438318	18 in.
438324	24 in.

Connectors

SharkBite Max™ Water Heater Connector

Features and benefits

- Fastest way to connect PEX, Copper, CPVC, PE-RT or HDPE SDR-9 pipe*
- Half the insertion effort, double the burst pressure**
- Can be installed on wet lines and pressure tested immediately
- Stainless steel retainer adds strength and durability
- High-performance DZR lead-free brass body
- No special tools, crimping, soldering or glue required
- Can be rotated after installation
- No tube liner required for PEX



URSS3088FX12



URSS3134FX18

Part #	Description
URSS3088FX12	3/4 in. x 3/4 in. FIP x 12 in.
URSS3088FX18	3/4 in. x 3/4 in. FIP x 18 in.
URSS3134FX18	3/4 in. x 3/4 in. MIP x 18 in.
URSS3088FX24	3/4 in. x 3/4 in. FIP x 24 in.

* SharkBite push-to-connect fittings are the fastest when compared to other conventional plumbing methods.
 ** Comparison relates to 1st generation SharkBite push-to-connect products.

SharkBite Max™ Brass Push Corrugated Water Softener Connector

Features and benefits

- Fastest way to connect PEX, Copper, CPVC, PE-RT or HDPE SDR-9 pipe*
- Half the insertion effort, double the burst pressure**
- Can be installed on wet lines and pressure tested immediately
- Stainless steel retainer adds strength and durability
- High-performance DZR lead-free brass body
- No special tools, crimping, soldering or glue required
- Can be rotated after installation
- No tube liner required for PEX



Part #	Description
URSS3086FX24	3/4 in. x 1 in. FIP x 24 in.

* SharkBite push-to-connect fittings are the fastest when compared to other conventional plumbing methods.
 ** Comparison relates to 1st generation SharkBite push-to-connect products.

Connectors

SharkBite™ Stainless Steel Water Heater Connector

Features and benefits

- Approved for electric and gas water heaters with flue vent
- Can be used as an alternative to hard piping
- Compatible with PEX, Copper, CPVC and PE-RT pipe
- No special tools, crimping, glue or soldering is needed
- Can be installed in wet lines
- Can be rotated for easier and faster installation
- Ideal for working in tight spaces
- Remove using a Disconnect Clip or Disconnect Tongs (both sold separately)



Part #	Description
SS3096FLEX24LF	1 in. x 3/4 in. x 24 in.

Connectors

Eastman™ WaterFlex™ FIP x FIP Connector

Features and benefits

- Corrugated stainless steel
- Nickel-plated brass nuts
- High-quality EPDM gasket

3/4 in. FIP x 1 in. FIP

Part #	Description
437512	12 in.
437515	15 in.
437518	18 in.
437524	24 in.

1 in. FIP x 1 in. FIP

Part #	Description
447512	12 in.
447515	15 in.
447518	18 in.
447524	24 in.

1-1/4 in. FIP x 1-1/4 in. FIP

Part #	Description
432118	18 in.
432124	24 in.

1-1/2 in. FIP x 1-1/2 in. FIP

Part #	Description
432218	18 in.
432224	24 in.

2 in. FIP x 2 in. FIP

Part #	Description
432318	18 in.
432324	24 in.



437512



447512



432118



432218



432318



Braided Stainless Steel Flexible Connectors

Braided Connectors
Braided Swivel Connectors

24

27



Braided Connectors

SharkBite Max™ Brass Push Water Heater Connector with Ball Valve

Features and benefits

- Fastest and easiest way to connect water heater to hot and cold water lines
- No PEX tube liner for smoother connection & less insertion force
- Compatible with PEX, copper, CPVC PE-RT, or HDPE Pipe
- Approved for electric and gas water heaters with flue vent
- Requires no special tools to install on hot or cold-water lines
- Can be installed on wet or dry lines pressure tested immediately

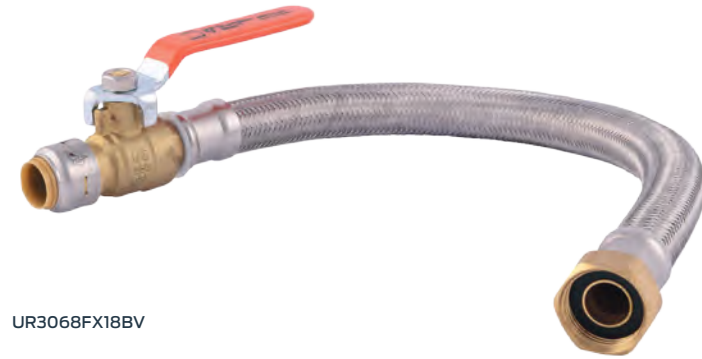

UR3068FX18BV

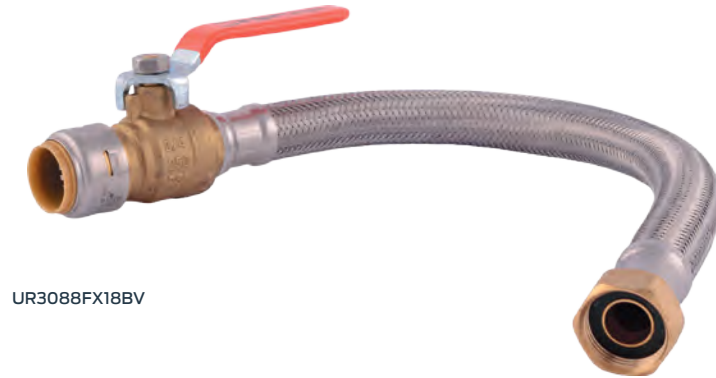

UR3088FX18BV

Part #	Description
UR3068FX18BV	1/2 in. x 3/4 in. FIP
UR3088FX18BV	3/4 in. x 3/4 in. FIP

Braided Connectors

SharkBite Max™ Brass Push Water Heater Connector

Features and benefits

- Fastest and easiest way to connect water heater to hot and cold water lines
- No PEX tube liner for smoother connection & less insertion force
- Compatible with PEX, copper, CPVC PE-RT, or HDPE Pipe
- Approved for electric and gas water heaters with flue vent
- Requires no special tools to install on hot or cold-water lines
- Can be installed on wet or dry lines pressure tested immediately



UR3068FX12



UR3088FX24

Part #	Description
UR3068FX12	1/2 in. x 3/4 in. FIP
UR3068FX15	1/2 in. x 3/4 in. FIP
UR3068FX18	1/2 in. x 3/4 in. FIP
UR3068FX24	1/2 in. x 3/4 in. FIP
UR3088FX12	3/4 in. x 3/4 in. FIP
UR3088FX15	3/4 in. x 3/4 in. FIP
UR3088FX18	3/4 in. x 3/4 in. FIP
UR3088FX24	3/4 in. x 3/4 in. FIP

Braided Connectors

SharkBite Max™ Brass Push Water Softener Connector

Features and benefits

- Fastest way to connect PEX, Copper, CPVC, PE-RT or HDPE SDR-9 pipe*
- Half the insertion effort, double the burst pressure**
- Can be installed on wet lines and pressure tested immediately
- Stainless steel retainer adds strength and durability
- High-performance DZR lead-free brass body
- No special tools, crimping, soldering or glue required
- Can be rotated after installation
- No tube liner required for PEX



Part #	Description
UR3086FX24	3/4 in. x 1 in. FIP

*SharkBite push-to-connect fittings are the fastest when compared to other conventional plumbing methods.
 **Comparison relates to 1st generation SharkBite push-to-connect products.

Braided Swivel Connectors

Eastman™ Steel-Flex™ 3/4 in. x 3/4 in. Connector

Features and benefits

- Corrugated stainless steel
- Nickel-plated brass nuts
- Nitrile rubber sealing washer

3/4 in. FIP Swivel x 3/4 in. FIP Swivel

Part #	Description
48250	12 in.
48262	15 in.
48251	18 in.
48252	24 in.

3/4 in. FIP Swivel x 3/4 in. MIP Rigid

Part #	Description
48573	12 in.
48254	18 in.
48255	24 in.

3/4 in. Compression x 3/4 in. FIP Swivel

Part #	Description
48264	15 in.
48257	18 in.
48258	24 in.

3/4 in. Compression x 3/4 in. MIP Rigid

Part #	Description
48259	12 in.
48260	18 in.
48261	24 in.



48250



48573



48264



48259

Water Heater Installation

Thermal Expansion Relief Valve	30
Thermal Expansion Tanks	30
Expansion Tank Tee	31
Expansion Tank Mounting Brackets	31
CashAcme™ Thermostatic Mixing Valves	32
Vacuum Relief Valve	33
Gas Connectors	34
CashAcme™ Tankless Installation Kit	35
Tankless Service Valve Kit	35
Runoff Tube	36
Drain Elbow	37
Dip Tube	37
Dielectric Unions	38
Heat Trap Nipples	38
Earthquake Straps	39
Water Heater Sheds	40
Water Heater Pan Fitting	41



Thermal Expansion Relief Valve

SharkBite™ Thermal Expansion Relief Valve

Features and benefits

- Instant push-fit connections for increased ease of use
- Replace an expansion tank, shut-off valve, and fitting with one product
- Certified to IGC 128, IAPMO/ANSI Z1157, NSF/ANSI/CAN 61, NSF/ANSI 372, and CSA B125.3 listed by IAPMO and CSA
- Assembled and tested in the USA



Part #	Description
25704LF	3/4 in. x 3/4 in. x 1/2 in. Outlet

Thermal Expansion Tanks

Eastman™ Thermal Expansion Tank

Features and benefits

- Factory charged at 40 psi
- 304 Stainless steel system connection
- Butyl rubber diaphragm
- Max operating temp. 210°F
- Max working pressure 150 psi
- 3/4 in. MIP connection
- 7-Year warranty



Part #	Description
60022	2 Gallon
60023	4.5 Gallon
60008	SS Expansion Tank

Expansion Tank Tee

Eastman™ Expansion Tank Tee

Features and benefits

- 360° swivel design for versatile tank and inlet setup
- Accommodates flex line attachments to meet code
- Can be mounted vertically or horizontally (support required)
- Tank sizes range from 2-10 gallons



Part #	Description
26090Z	1-1/4 in. x 1-1/4 in. x 1-1/2 in.

Expansion Tank Mounting Brackets

HoldRite™ Quick Strap™ Expansion Tank Mounting Bracket

Features and benefits

- Made of galvanized and stainless steel
- Support tanks up to 5 gallons and 13 in. in diameter
- Includes mounting bracket, two support straps and two screws

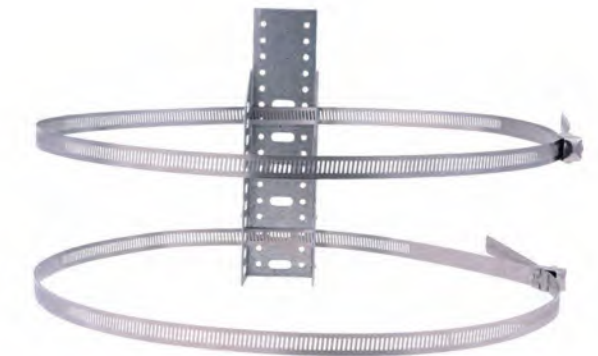

Part #	Description
QS-U-C	Contractor packaging

Thermostatic Mixing Valves

CashAcme™ Tank Booster™ PRO Thermostatic Mixing Valve

Features and benefits

- Lockable adjustment
- Recirculation port
- Non-returns integral to both inlets
- Filters for both inlets
- Hot inlet and cold inlet supplied
- Temperature guage
- Adjustable temperature range: 95°F (35°C) – 130°F (54°C)
- Factory setting: 115–120°F (46–48.9°C)



Part #	Description
24643	3/4 in. Corrugated hose
24644	3/4 in. Braided hose

Vacuum Relief Valve

CashAcme™ VR20 Vacuum Relief Valve

Features and benefits

- It works by preventing internal vacuum conditions that could result in burned out heaters and/or collapsed storage tanks
- Installed on the cold water supply line, the Cash Acme VR20 closes tightly under pressure and opens at a 1 in. mercury vacuum
- Atmosphere admitted to the system breaks the vacuum, preventing collapse of the storage tank



22397LF

Part #	Description
22397LF	VR20 Drilled Vent w/ dust cover
22398LF	VR20 Drilled Vent w/ dust cover

Gas Connectors

Eastman™ 3/4 in. FIP x 3/4 in. MIP 24 in. Stainless Steel Installation Kit

Features and benefits

- For tankless water heaters with gas requirements up to 290,000 BTUs per hour
- Contains one 7/8 in. outer diameter x 24 in. polymer coated stainless steel gas connector
- CSA approved for indoor and outdoor use
- Quick and easy installation

Includes

- 24 in. 1 in. OD epoxy-coated gas range connector
- 1 in. FIP fitting
- 1 in. MIP (Tapped 3/4 in. FIP) fitting
- 3/4 in. FIP fitting
- 3/4 in. MIP (Tapped 1/2 in. FIP) fitting
- Leak detector solution
- Thread sealant



Part #	Description
40YE57565524K	Gas Connector Kit

Eastman™ Brass Gas Ball Valve – Straight

Features and benefits

- Lever handle
- For use with liquefied petroleum, natural gas and air mixtures up to 175 PSI
- Brass body



60013

Part #	Description
60013	1 in. FIP
60009	1/2 in. FIP
60011	3/4 in. FIP

Tankless Installation Kit

CashAcme™ Tankless Water Heater Installation Kit

Features and benefits

- Unique 3-way ball valve design provides a single turn level handle for ease of use in tight spaces
- Color-coded handles for easy identification of hot and cold shut off valves
- Compact design works in a variety of installations

Includes

- Hot water shut off valve
- Cold water shut off valve
- Pressure relief valve



Part #	Description
25760	Tankless Water Heater Kit with NPT Connections

Tankless Service Valve Kit

Eastman™ Tankless Water Heater Service Valve Kit

Features and benefits

- Heavy-duty bronze and forged lead-free brass construction
- Versatile union tank connections
- 150 psi pressure relief valve included
- 600 psi WOG rating
- Tethered capped drain valves allow for quick water heater servicing

60204 Includes

- Color-coded hot valve
- Color-coded blue valve
- Pressure relief valve

60205 Includes

- Color-coded hot valve
- Color-coded blue valve
- Pressure relief valve

60206 Includes

- Color-coded hot valve
- 2 color-coded blue valves
- Pressure relief valve



60204

Part #	Description
60204	3/4 in. FNPT Union x 3/4 in. FIP Service Valves
60205	3/4 in. FNPT Union x 3/4 in. Sweat Service Valves
60206	3/4 in. FNPT Union x 3/4 in. FIP Service Valves (2 Cold Valves)

Runoff Tube

Eastman™ Side-Mount Water Heater Runoff Tube

Features and benefits

- Attaches to temperature and pressure relief valve on side of water heater
- Can be discharged into water heater pan or directly into drain
- 3/4 in. NPT swivel connection
- Can be cut to length

Part #	Description
60062	60 in. Side-Mount Runoff Tube



Detail

Eastman™ Top-Mount Water Heater Runoff Tube

Features and benefits

- Attaches to temperature and pressure relief valve on top of water heater
- Can be discharged into water heater pan or directly into drain
- 3/4 in. NPT swivel connection
- Can be cut to length

Part #	Description
60063	59 in. Top-Mount Runoff Tube



Detail

Drain Elbow

Eastman™ Adjustable Drain Elbow

Features and benefits

- Made of durable plastic
- Cut to fit
- Used to connect to runoff tube for top-mount water heaters



Part #	Description
60144	3/4 in. MIP x 3/4 in. FIP x 13 in. Length

Dip Tube

Eastman™ Water Heater Dip Tube

Features and benefits

- Gasket included
- Fits most brands of water heaters



Part #	Description
60067	52 in. Polypropylene Flared Dip Tube

Heat Trap Nipples

Eastman™ Heat Trap Nipples

Features and benefits

- 1 pair – hot and cold
- Galvanized
- Bagged with barcode



Part #	Description
60098	3/4 in. MIP x 3 in. Length

Dielectric Unions

Eastman™ Dielectric Union

Features and benefits

- Used to transition between steel pipe and copper pipe
- Maximum PSI is 250, 180°F
- Gasket is made of silicone rubber and a nylon insert
- IPS Connection and nut are both made of steel
- Constructed of a highly-durable brass to minimize corrosion
- Nuts are constructed of steel

Part #	Description
20501	1/2 in. FIP x 1/2 in. Solder
EZ-20513	3/4 in. FIP x 1/2 in. Solder
EZ-20503	3/4 in. FIP x 3/4 in. Solder
20515	3/4 in. MIP x 3/4 in. Solder
20505	1 in. FIP x 1 in. Solder
20507	1-1/4 in. FIP x 1-1/4 in. Solder
EZ-20509	1-1/2 in. FIP x 1-1/2 in. Solder
EZ-20511	2 in. FIP x 2 in. Solder



20515

Eastman™ Dielectric Nipple

Features and benefits

- Teflon lined to prevent corrosion
- Certified to be a low-lead product
- Galvanized Nipple

Part #	Description
60095	3/4 in. MIP x 3 in. Length



Earthquake Straps

HoldRite™ Galvanized Steel Water Heater Restraint

Features and benefits:

- Available in a galvanized or powder-coated steel strap style.
- Comes in different sizes to support water heaters with different gallon capacities.

Includes

- Straps
- J-Clips
- Lag Bolts
- 3/8 in. Carriage Bolts
- 3/8 in. Hex Nuts



Part #	Description
QS-120	24 gage CRS, galvanized. Up to 120 gal. 54 in. x 1-1/2 in.
QS-50	24 gage CRS, galvanized. Up to 80 gal. 38 in. x 1-1/2 in.
QS-50-P	24 gage CRS, galvanized. Up to 80 gal. 38 in. x 1-1/2 in.
QS-50-D	24 gage, White Powder Coated Steel. Up to 80 gal. 38 in. x 1-1/2 in.
QS-50-S	24 gage CRS, galvanized. Up to 80 gal. 38 in. x 1-1/2 in.
HR-80-180	180°. Galvanized Steel
HR-80-360	360°. Galvanized Steel

Water Heater Sheds

HoldRite™ Quick Shed™ Water Heater Enclosure

Features and benefits

- Constructed of galvanized steel
- Superior front panel design provides access door for service
- Anchor points at the rear of the enclosure allow for optional attachment to the adjacent building structure
- Available in a range of sizes, from 24 in. to 30 in.
- Back panel options available
- Complies with code requirements regarding venting for combustion air

Part #	Description
QS-E24	24 in. x 74 in. x 24 in.
QS-E30	30 in. x 74 in. x 30 in.



HoldRite™ Quick Shed™ Water Heater Enclosure Vent Cap

Features and benefits

- Allows air circulation
- Prevents excess heat accumulation
- Keeps most rain and weather out

Part #	Description
QS-EVC	Galvanized Steel

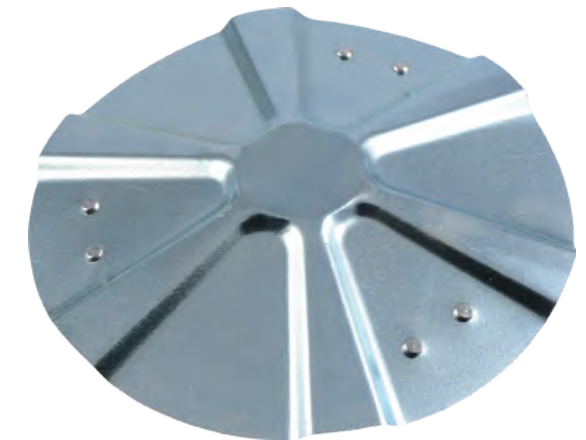

Water Heater Pans and Stands

Plastic Water Heater Pans	44
Aluminum Water Heater Pans	44
Galvanized Water Heater Pans	45
Water Heater Stands	45



Plastic Water Heater Pans

Eastman™ Plastic Water Heater Pan

Features and benefits

- Black plastic
- Includes drain fittings
- Use with electric water heaters

PVC fitting

Part #	Description
60076	20 in. ID x 22 in. OD
60091	22 in. ID x 24 in. OD
60082	24 in. ID x 26 in. OD
60083	26 in. ID x 28 in. OD
60078	28 in. ID x 30 in. OD
60077	30 in. ID x 32 in. OD

CPVC fitting

Part #	Description
60076CPN	20 in. ID x 22 in. OD - w/ fittings
60091CPN	22 in. ID x 24 in. OD - w/ fittings
60082CPN	24 in. ID x 26 in. OD - w/ fittings
60083CPN	26 in. ID x 28 in. OD - w/ fittings
60078CPN	28 in. ID x 30 in. OD - w/ fittings
60077CPN	30 in. ID x 32 in. OD - w/ fittings



60076

Aluminum Water Heater Pans

Eastman™ Aluminum Water Heater Pan

Features and benefits

- Aluminum
- Includes drain fittings
- Use with gas water heaters or electric

PVC fitting

Part #	Description
60080	20 in. ID x 22 in. OD
60086	22 in. ID x 24 in. OD
60079	24 in. ID x 26 in. OD
60089	26 in. ID x 28 in. OD
60087	28 in. ID x 30 in. OD
60094	30 in. ID x 32 in. OD

CPVC fitting

Part #	Description
60080CPN	20 in. ID x 22 in. OD - w/ fittings
60086CPN	22 in. ID x 24 in. OD - w/ fittings
60079CPN	24 in. ID x 26 in. OD - w/ fittings
60089CPN	26 in. ID x 28 in. OD - w/ fittings
60087CPN	28 in. ID x 30 in. OD - w/ fittings
60094CPN	30 in. ID x 32 in. OD - w/ fittings



60080

Water Heater Pan Fitting

Eastman™ Water Heater Pan Fitting

Features and benefits

- Fits Eastman™ water heater pans



Part #	Description
88350	1 in. Hub x 1 in. MIP – PVC
88351	1 in. Hub x 1 in. MIP – CPVC

Galvanized Water Heater Pans

Eastman™ Galvanized Water Heater Pan

Features and benefits

- Protect floors from damage due to water heater leaks
- For gas or electric water heaters
- Square design

Includes

- Comes with PVC drain fitting



Part #	Description
69050	30 in. x 30 in. x 2 in.
69052	24 in. x 24 in. x 2 in.

Water Heater Stands

HoldRite™ Quick Stand™ Water Heater Floor Stand

Features and benefits:

- Engineered and lab tested to meet Uniform Plumbing Code (UPC) and International Plumbing Code (IPC) requirements
- Unassembled and pre-assembled options available
- Constructed of galvanized steel
- Available in a range of sizes to accommodate different water heater weights

Part #	Description
40-S-22-U	22 in. x 22 in., up to 52 gal, 650 lbs
40-S-24-U	24 in. x 24 in., up to 100 gal, 1,200 lbs
40-S-30-U	30 in. x 30 in., up to 100 gal, 1,350 lbs
40-S-34-U	34 in. x 34 in., up to 120 gal, 2,000 lbs



Eastman™ Water Heater Stand

Features and benefits

- Safety clips for screwing to wall or floor included

Part #	Description
86278	21 in. x 21 in., up to 60gal, 650 lbs
86279	24 in. x 24 in., up to 100 gal, 1200 lbs



Water Heater Repair

Anode Rods	50
Drain Valves	51
Thermocouples	51
Temperature and Pressure Relief Valves	52
Pressure Relief Valves	52
Electrical Continuity Tester	53
Tune-Up Kit	54
Heating Elements	54
Tools	56
Adapter Kit	57
Replacement Parts	57
Thermostats	58



Anode Rods

Eastman™ 42 in. Aluminum Anode Rod

Features and benefits

- Helps prolong the life of your water heater by protecting against corrosion
- 5/8 in. Aluminum constructed rod
- 3/4 in. NPT fitting – hex-head
- Fits most brands of water heaters



Part #	Description
60066	3/4 in. NPT Hex-Head

Eastman™ 45 in. Flexible Anode Rod

Features and benefits

- Helps prolong the life of your water heater by protecting against corrosion
- Flexible 4 sections with stainless steel links
- Fits most brands of water heaters



Aluminum

Part #	Description
60145	3/4 in. NPT Hex-Head

Magnesium

Part #	Description
60296	1-1/6 in. Hex Head

Eastman™ 42 in. Flexible Anode Rod

Features and benefits

- Manufactured with flexible carbon steel cable and 4 sections with a diameter of 5/8 in.
- Measures 42 in. in length
- Equipped with a 3/4 in. NPT nipple

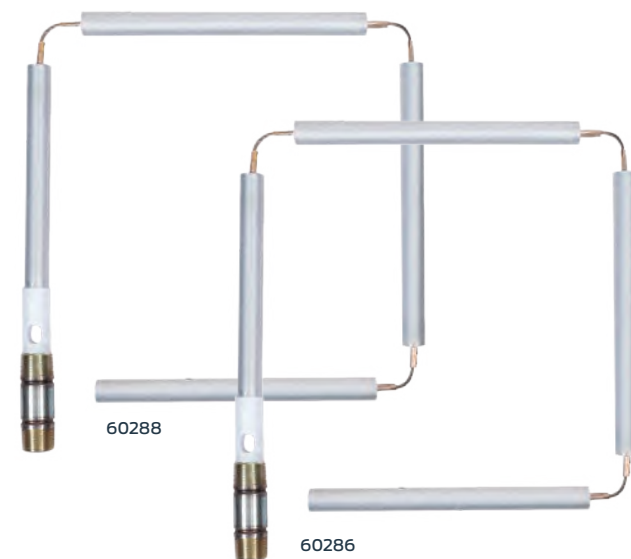

Aluminum

Part #	Description
60288	3 in. Nipple
60289	5 in. Nipple

Magnesium

Part #	Description
60286	3 in. Nipple
60287	5 in. Nipple

Drain Valves

Eastman™ Drain Valve

Features and benefits

- 3/4 in. MIP x 3/4 in. MHT

Brass

Part #	Description
60092LF	2-1/4 in. Long Shank (Brass)

Nylon

Part #	Description
60093	2-1/2 in. Long Shank (Nylon)

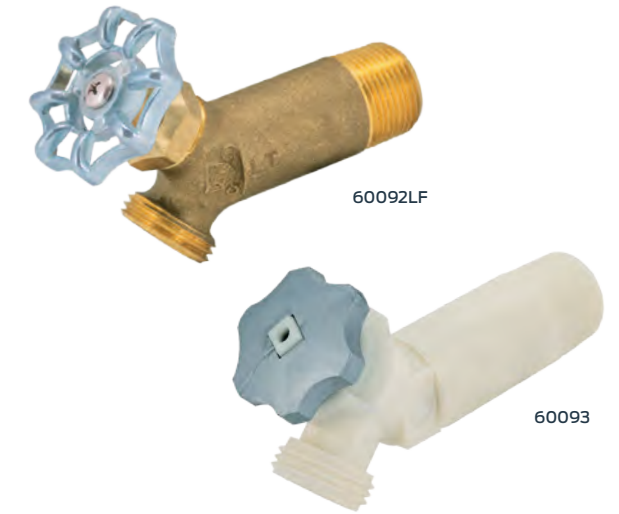

Thermocouples

Eastman™ Thermocouples

Features and benefits

- Stainless steel head and weld at tip to provide reliable performance
- Designed to simplify installation on automatic controls and burners
- For use with gas water heaters



Part #	Description
60035	18 in.
60036	24 in.
60037	30 in.
60038	36 in.
60041	48 in.

Eastman™ Thermocouple – Procom

Features and benefits

- Replacement for Vent-free ProCom Heaters
- MFG Replacement – TC-P-04

Part #	Description
60044	39 in.



Temperature and Pressure Relief Valves

Cash Acme™ NCLX Temperature & Pressure Relief Valve

Features and benefits

- Features an inert thermal element coating, providing effective isolation from mineral deposits and galvanic corrosion
- Constructed with a cast bronze body, brass and stainless steel internal parts, a silicone seat disc, and a stainless steel spring
- Comes standard with a test lever, and automatically reseats after temperature or pressure relief

Part #	Description
15912-0150	1/2 in. – NCLX-5, CSA only, 150 psi
15836-0150	3/4 in. – NCLX-5, 150 psi
19783-0150	3/4 in. – NCLX-5LX, 150 psi



Pressure Relief Valves

CashAcme™ FWL-2 Tankless Pressure-only Safety Relief Valve

Features and benefits

- Designed specifically for the protection of hot water supply systems from over-pressure conditions due to thermal expansion
- Fully automatic operation with the valve reseating after pressure relief
- Can be installed directly on the tank or in a tee, suitable for both hot and cold sides of the water heater
- Constructed with a bronze body, brass and stainless steel internal parts, a silicone seat disc, and a stainless steel pressure spring
- Features a compact and economical design for robust and reliable performance

Part #	Description
14737-0150	3/4 in. - FWL, 2,150 psi



Pressure Relief Valves

CashAcme™ FW Pressure Relief Valve

Features and benefits

- Ideal for commercial and industrial applications, including thermal expansion protection, static pressure and over-pressure relief, and low capacity pump relief
- Designed for uses requiring tight shut-off, ensuring reliable performance
- Non-code compliant valves for cost-effective pressure relief solutions

Part #	Description
09553-0125	1/2 in.
09554 -0125	3/4 in.



Cash Acme™ FWC Pressure Relief Valve

Features and benefits

- Features a calibrated adjusting screw for occasional pressure setting adjustments without a pressure gauge
- Constructed with bronze bodies, male inlets, female outlets, silicone seats, and stainless steel springs
- Suitable for commercial and industrial applications including thermal expansion protection, static pressure and over-pressure relief, low capacity pump relief, and other similar uses requiring tight shut-off
- Valves are non-code compliant

Part #	Description
09563-0125LF	1/2 in. FWC Adjustable Pressure Only
09564-0125LF	3/4 in. FWC Adjustable Pressure Only



Electrical Continuity Tester

Eastman™ Electrical Continuity Tester

Features and benefits

- Designed for use on electric water heaters
- Tests for continuity in non-energized circuits
- Requires 2 AA batteries (included)



Part #	Description
60039	Electrical Tester for Electric Water Heaters

Tune-Up Kit

Eastman™ Electric Water Heater Tune-up Kit

Features and benefits

- Fits most models of water heaters
- Most common repair items for an electric water heater system
- Adjustable temperature range from 90°F to 150°F

Includes

- 4,500-Watt, 240-Volt water heater screw-in elements
- Therm-O-Disc style 240-Volt lower thermostat
- Therm-O-Disc style upper thermostat

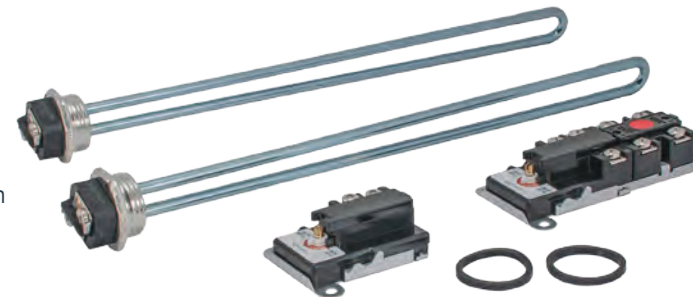

Part #	Description
60178	Electric Water Heater Tune-Up Kit

Heating Elements

Eastman™ Water Heater Element – High-Watt Density

Features and benefits

- Copper sheath-tinned

Screw mount with gasket

Part #	Description
60047	120V x 1440W Straight
60061	120V x 1500W Straight
60124N	120V x 2000W Straight
60054	240V x 1500W Straight
60125N	240V x 2500W Straight
60056	240V x 3000W Straight
60122N	240V x 3500W Straight
60052	240V x 3800W Straight
60057N	240V x 4500W Straight
60068	240V x 5500W Straight
60069	240V x 5500W Fold Back

Universal flange mount with gasket

Part #	Description
60060	120V x 1500W Straight
60046	240V x 1500W Straight
60053	240V x 3000W Straight
60142	240V x 3800W Straight
60058	240V x 4500W Straight
60059	240V x 5500W Fold Back



60057N

60122N

60069

Eastman™ Water Heater Element – Low-Watt Density

Features and benefits

- Copper sheath-tinned
- Screw mount with gasket

Part #	Description
60065	240V x 4500W Fold Back



Heating Elements

Eastman™ Water Heater Element – Ultra Low-Watt Density

Features and benefits

- Incoloy nickel based sheath
- Screw mount with gasket



Part #	Description
60128	240V x 4500W Fold Back
60126	240V x 5500W Fold Back

Tools

Eastman™ Heavy-Duty Water Heater Element Wrench Socket – Chrome

Features and benefits

- Heavy-duty steel with a chrome-plated finish to resist corrosion and provide extra strength and durability
- Designed for use with a screwdriver to remove and replace residential screw-in water heater elements quickly and easily
- Built-in torque holes for extra leverage
- 1-1/2 inch in diameter and includes a 3/4 inch to 1/2 inch adapter



Part #	Description
45058	Element Socket

Eastman™ Water Heater Element Wrench With Bar Handle

Features and benefits

- Constructed of a durable metal to provide extra strength
- Includes a bar handle for extra reach in confined spaces
- Designed to fit most screw-in type elements
- Ideal for use with a screwdriver



Part #	Description
45059	Element Wrench

Adapter Kit

Eastman™ Water Heater Element Adapter Kit

Features and benefits

- Adapts flat, universal or round flange element with a standard screw-in element

Includes

- Screw-in element gasket
- Four-hole element gasket
- 5/16 in.-18 x 5/8 in. long hex-flange-head bolts
- 2-1/2 in. four-bolt adapt-a-flange
- Thermostat bracket



Part #	Description
60049	Water Heater Element Adapter Kit

Replacement Parts

Eastman™ Universal Water Heater Element Gasket Kit

Includes

- Flange element gasket
- Four-hole element gasket
- Screw-in element gasket



Part #	Description
60050	Water Heater Element Gasket Kit

Replacement Parts

Eastman™ Replacement Water Heater Connector Washer

Features and benefits

- Use with 3/4 in. FIP connection only



Part #	Description
60228	Black Rubber Washer – 4 Pack
60229N	Black Rubber Washer – 50 Pack

Thermostats

Eastman™ Apcom Thermostat

Features and benefits

- With high-limit control
- Built-in safety switch to help prevent water heater from overheating
- Includes terminal protector
- Adjustable temperature range: 110° F to 160° F

Part #	Description
60071	Single-Element Water Heater Thermostat
60073	Single-Throw 120V/240V Lower Thermostat
60075	Double-Throw 120V/240V Upper Thermostat

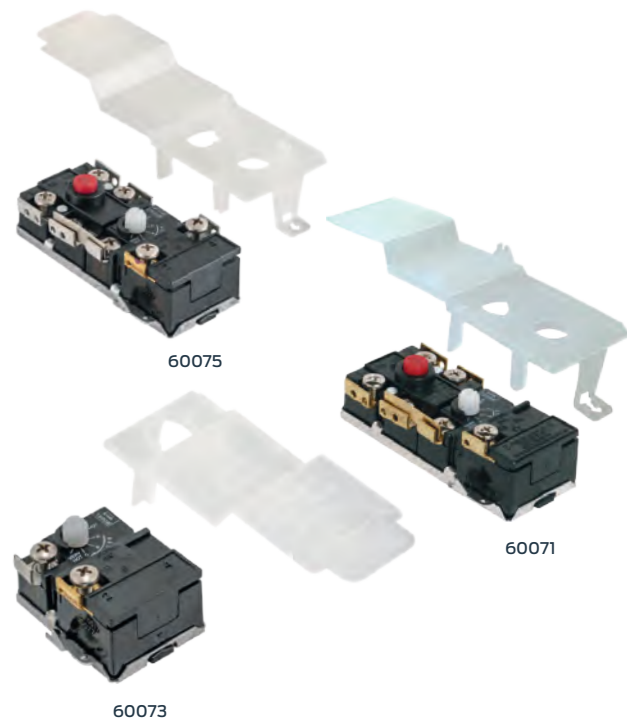

Thermostats

Eastman™ Therm-O-Disc Thermostat

Features and benefits

- With high-limit control
- Built-in safety switch to help prevent water heater from overheating
- Fits most brands of water heaters
- Adjustable temperature range: 90° F to 150° F

Part #	Description
60174N	Single-Element Thermostat for Water Heaters
60170N	Lower Thermostat for Dual-Element Water Heaters
60172N	Upper Thermostat for Dual-Element Water Heaters



Alphabetic Index

A

3/4 in. FIP Swivel x 3/4 in. FIP Swivel	27
3/4 in. x 3/4 in. Connectors	17
42 in. Aluminum Anode Rod	48
42 in. Flexible Anode Rod	48
45 in. Flexible Anode Rod	48
Adjustable Drain Elbow	36
Aluminum Water Heater Pan	43
Apcom Thermostat	56

B

Braided Water Heater Connector	25
Braided Water Heater Connector with Ball Valve	24
Braided Water Softener Connector	26

C

Corrugated Water Softener Connector	19
-------------------------------------	----

D

Dielectric Nipple	37
Dielectric Union	38
Drain Valve	51

E

Electrical Continuity Tester	52
Electric Water Heater Installation Kit	15
Electric Water Heater Tune-up Kit	52
Expansion Water Heater Connector	16

F

FIP x FIP Connectors	20
FWL-2 Tankless Pressure-only Safety Relief Valve	50

G

Galvanized Steel Water Heater Restraint	38
Galvanized Water Heater Pan	44
Gas Water Heater Installation Kit	14

H

Heat Trap Nipple	36
Heavy-Duty Water Heater Element Wrench Socket – Chrome	54

N

NCLX Temperature & Pressure Relief Valve	50
--	----

P

Mini Tankless Expansion Tank	30
------------------------------	----

Q

Quick Shed™ Water Heater Enclosure	39
Quick Shed™ Water Heater Enclosure Vent Cap	39
Quick Stand™ Water Heater Floor Stand	45
Quick Strap™ Expansion Tank Mounting Bracket	31

R

Plastic Water Heater Pan	42
--------------------------	----

S

Replacement Water Heater Connector Washer	56
Stainless Steel Corrugated Flexible Water Heater Connection Kit	14
Stainless Steel Corrugated Water Softener Connector	19

T

Side-mount Water Heater Runoff Tube	36
Tank Booster™ PRO Thermostatic Mixing Valve	32
Tank Booster™ Thermostatic Mixing Valve	32
Tankless Water Heater Installation Kit	34
Tankless Water Heater Service Valve Kit	34
Thermal Expansion Relief Valve	30
Thermal Expansion Tank	31
Thermocouple – Procom	49
Thermocouples	49
Therm-O-Disc Thermostat	57

U

Top-mount Water Heater Runoff Tube	35
------------------------------------	----

V

Universal Water Heater Element Gasket Kit	55
---	----

W

VR20 Vacuum Relief Valve	32
Water Heater Connection Kit	15
Water Heater Dip Tube	36
Water Heater Element Adapter Kit	55
Water Heater Element Wrench With Bar Handle	54
Water Heater Pan Fitting	44
Water Heater Safety Straps	38
Water Heater Stand	45



Connect with us



Certifications

The most up-to-date certifications and warranty can be found at eastmanplumbing.com

Tel: 1-877-700-4242 | Fax: 1-877-700-4280
Manufactured & Distributed by Reliance Worldwide Corporation®.
EM_CAT_Water Heater Installation & Repair_1284252147_0125